



Type(s)

Project

Date

Notes

**GENERAL INFORMATION**

ETC’s Desire Series D40XT Studio lighting fixture puts the newest technology in high-output white-light LEDs into a sealed IP66 outdoor-rated enclosure to create an ideal luminaire for video, film and other ‘white light only’ applications. Its watertight construction makes it ideal for location lighting. Three different LED options give the user a choice for just the right white light output for the job. The D40XT Studio offers a rugged die-cast enclosure; noiseless, no fan cooling; multiple lens options and advanced user interface. The user interface enables easy configuration and specific features for video and film professionals. The fixture can be configured to operate under console control for studio systems or in stand-alone ‘no console required’ settings.

**D40XT Studio LED Array Options**

D40XT Studio fixtures offer three different LED array choices based on specific white-light functions. The D40XT Studio fixture is available with any one of the following color arrays (not interchangeable) to best suit the application.

- D40XT Studio HD – Studio HD combines warm white and cool white LEDs for variable color temperature mixing. Added to this are five carefully chosen LED colors from the x7 Color System to fill in the white LED spectral gaps. D40XT Studio HD provides the richest variable white light possible in an LED fixture.
- D40XT Studio Daylight – Studio Daylight contains forty 5600 K LEDs for high-intensity, non-variable cool-white output.
- D40XT Studio Tungsten – Studio Tungsten contains forty 3000 K LEDs for high-intensity, non-variable warm-white output.

**ORDERING INFORMATION**

**Selador D40XT Studio**

MODEL	DESCRIPTION
SELD40HO	D40 Studio HD wash fixture – IP66-rated fixture for high-intensity variable white light output with broad spectrum richness and color rendering
SELD40DO	D40 Studio Daylight wash fixture – IP66-rated fixture with all 5600 K emitters for single color, non-adjustable daylight output
SELD40TO	D40 Studio Tungsten wash fixture – IP66-rated fixture with all 3000 K emitters for single color, non-adjustable warm white output

Note: D40XT Studio luminaires ship with hanging yoke and attached leads equipped with watertight Molex power connectors and watertight DMX connectors. C-clamp, lenses or separate power lead are not included. Order DPA-M bare-end to Molex adaptors separately for XT luminaires if required.

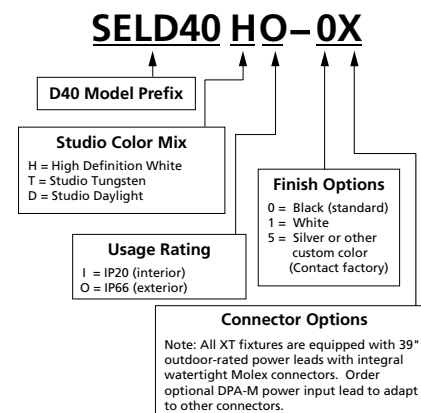

## PRODUCT SPECIFICATIONS

## Source

LED details	40 Lumileds LUXEON® Rebel LED
Max lumens	Studio HD: 3,194 Studio Daylight: 4,332 Studio Tungsten: 5,023
Lumens per watt	Studio HD: 33.2 Studio Daylight: 43.1 Studio Tungsten: 52.8
L70 rating (hours to 70% output)	50,000 hours

## Color

Colors used	Studio HD: Red, Amber, Green/Cyan, Blue, Warm White, Cool White Studio Daylight: White Studio Tungsten: White
Color temperature range	Studio HD: Studio Daylight: 3200 K Studio Tungsten: 5600 K
Calibrated array	Studio HD: Yes Studio Daylight: No Studio Tungsten: No
Red shift	Yes

## Optical

Beam angle range	8°–71°
Aperture size	7.5 in
Pattern projection	No
Pattern size	N/A
Camera flicker control/Hz range	Yes: 900–25,000 Hz
Notes	- Secondary lenses available for multiple beam-spread options - Sealed, factory-installed lenses available for permanent installations

## Control

Input method	DMX512 via watertight 5-pin XLR
Protocols	DMX512/RDM
Modes (footprint)	See page 5
RDM configuration	Yes
UI type	LCD
Local control	Yes
Onboard presets	Yes
Onboard sequences	Yes
Onboard effects	No
Fixture-to-fixture control	Yes
Notes	15-bit virtual dimming engine

## Electrical

Voltage range	100–240 VAC 50/60 Hz
Input method	Waterproof, 39 in power in and thru Requires power from non-dimmable source
Inrush	15 A at 120 V (First half-cycle) 40 A at 240 V (First half-cycle)
Fixtures per circuit*	10 (15 A may be fed on same circuit)
Wattage typical	110
Current draw	1/0.5 A

\*Note: All measurements are for 120 V, 60 Hz. Results may vary in different regions.

## Thermal

Ambient operating temp	-20°–40° C (-4°–104° F)
Fan (controllable)	No
Droop compensation	Yes
dB range	N/A
BTUs/hour	375.32

## Physical

Materials	Die-cast, all metal housing
Color options	Black, white, silver, or custom color
IP rating	IP66 for exterior, wet location use
Weight	6.4 kg (14 lb)
Included accessories	Hanging yoke, optional yoke/floor stand

## Warranty

Fixture	5 years
LED array	10 years

## Regulatory and Compliance

Approved regulatory standards	cETLus Listed Conforms to UL1598 Certified to CSA C22.2 No. 250.0 CE Compliant
-------------------------------	---

ETC utilizes a nationally recognized 3rd party lab for luminaire testing according to IES LM-84. See [etconnect.com/About/News/ETC-Fixture-Ratings-and-Warranties-Extended.aspx](http://etconnect.com/About/News/ETC-Fixture-Ratings-and-Warranties-Extended.aspx).

All LED sources experience some lessening of light output and some color shift over time. LED output will vary with thermal conditions. In individual situations, LEDs will be used for different durations and levels. This can eventually lead to minor alterations in color performance, necessitating slight adjustments to presets, cues or programs.

PRODUCT FEATURES



**NOISELESS, FAN-FREE**  
 Convection cooling for acoustically sensitive installations



**MULTIPLE LED ARRAY OPTIONS**  
 Also available in static white arrays

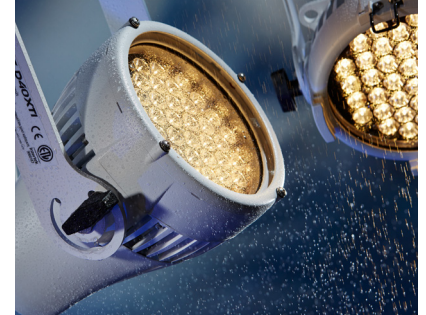

**WATERPROOF OUTDOOR-RATED POWER LEAD**  
 Lorem ipsum

COLOR METRIC INFORMATION

D40 STUDIO HD 3200 K TM-30-18

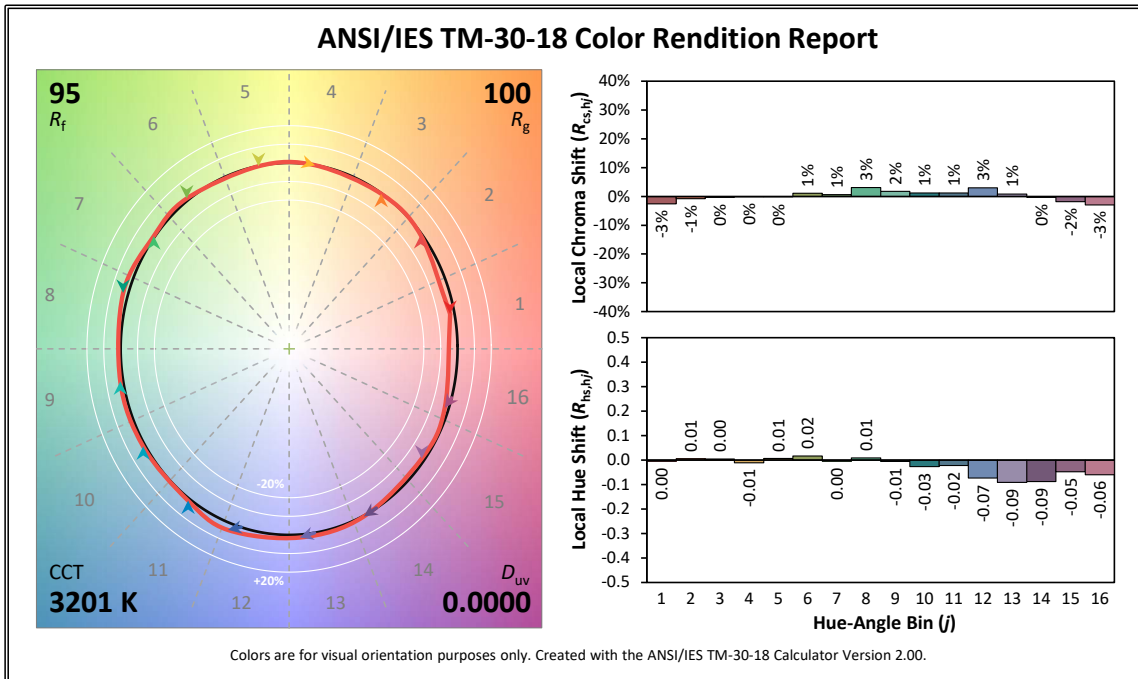

COLOR METRIC INFORMATION

D40 STUDIO HD 4500 K TM-30-18

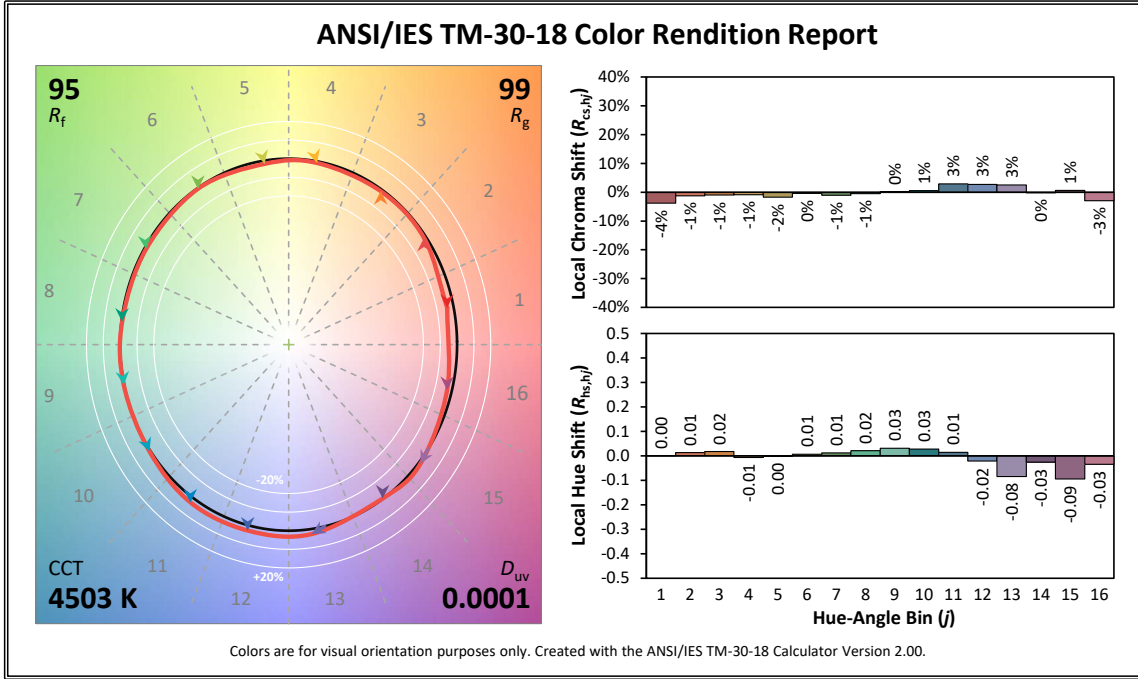

D40 STUDIO HD 5600 K TM-30-18

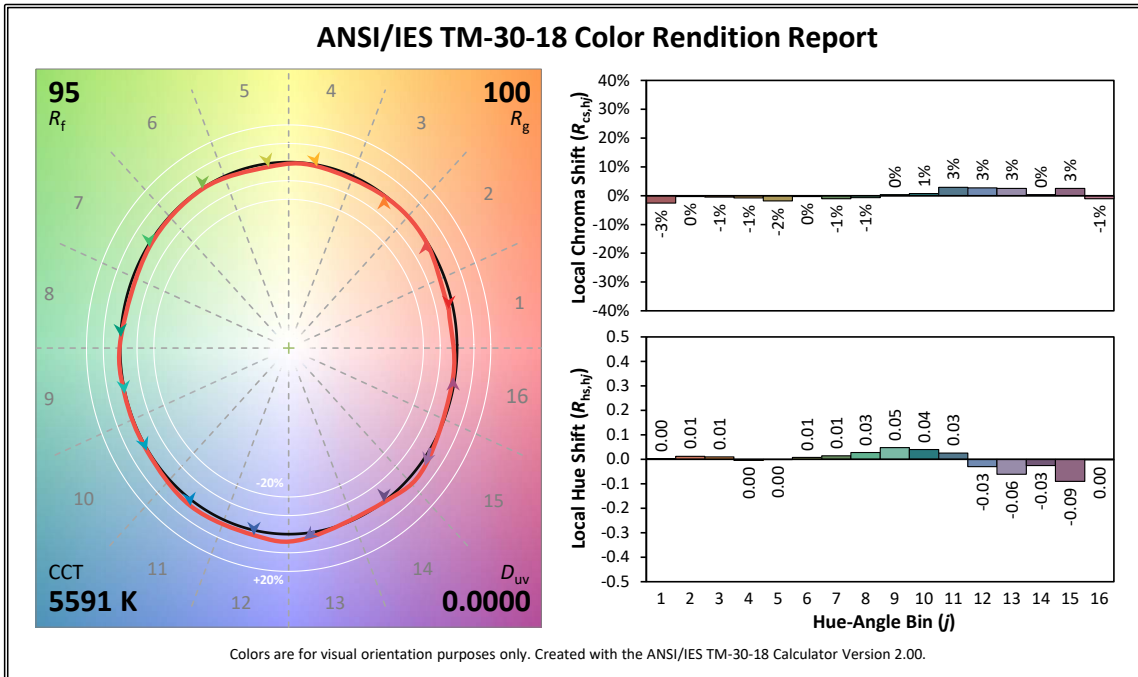

ADDITIONAL ORDERING INFORMATION

Secondary Lens Options

The following lenses are cut for D40 fixtures and create round, linear or oblong field patterns as described below. These lenses are not for use in Selador Classic (Vivid, Lustr+, etc.) fixtures.

Note: This is the same material as Selador Classic lenses

MODEL	DESCRIPTION:
<b>Narrow Linear Field</b>	Linear lenses may be combined to create desired field size
SELLVN-7.5	7.5 in Very narrow lens
SELLN-7.5	7.5 in Narrow lens
SELLM-7.5	7.5 in Medium lens
SELLW-7.5	7.5 in Wide lens
SELLEW-7.5	7.5 in Extra wide lens
<b>Round Field</b>	Any one of the following round lenses may be installed permanently in the fixture at the factory as a special order
SELRN-7.5	7.5 in Narrow lens (round field)
SELRM-7.5	7.5 in Medium lens (round field)
SELRW-7.5	7.5 in Wide lens (round field)
<b>Oblong Field</b>	
SELON-7.5	7.5 in Narrow lens (oblong field)
SELOM-7.5	7.5 in Medium lens (oblong field)
SELOW-7.5	7.5 in Wide lens (oblong field)

[http://www.etconnect.com/docs/docs\\_downloads/miscdocs/Desire\\_vs\\_PAR\\_EA\\_revB.pdf](http://www.etconnect.com/docs/docs_downloads/miscdocs/Desire_vs_PAR_EA_revB.pdf)

Typical Lens Field Profiles

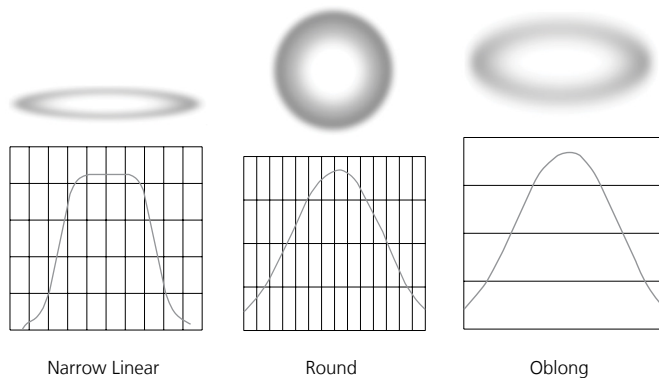

NOTES ABOUT LED LUMINAIRES

All LED sources experience some lessening of light output and some color shift over time. LED output will vary with thermal conditions. Based on the LED manufacturer's B50 L70 specification, a Selador luminaire will achieve ~70% of its initial output after 50,000 hours of typical usage. In individual situations, LEDs will be used for different durations and at different levels. This can eventually lead to minor alterations in color performance, necessitating slight adjustments to presets, cues or programs.

CRI AND CQS RATINGS

Desire fixtures were evaluated for CRI and CQS performance using measured output spectrum and optimized mix solutions for a best spectral match to black body sources at 3200 K and 5600 K.

All D40XT Studio luminaire versions provide excellent color rendering to the eye, particularly at higher color temperature settings such as 5600 K. In most cases the Duv is 0.000. A Duv rating of 0.000 indicates that the color mix used is exactly on the black body line, with no green or magenta tint.

Notes to Videographers:

- All Desire fixtures use Luxeon Rebel ES emitters specified by the strictest binning standards. However, on-camera LED response varies with different cameras and settings. Daylight LEDs can appear slightly greener than other 5600 K sources on camera.
- Fixtures with non-variable single-color daylight arrays such as Studio Daylight may use standard color correction filters (Rosco 3314, Rosco 3316 or similar) to achieve the desired on-camera result.
- Camera tests using your specific set up are recommended to determine the best configuration.

**CONTROL OPTIONS**

**Studio HD**

User settings on D40XT Studio fixtures allow multiple operational modes and settings for either console operation via DMX protocol or stand-alone operation. The expanded LCD display provides easy navigation to all possible settings and options. Some of the setting options are:

- Multiple DMX choices ranging from a simple RGB profile – which effectively controls all seven LED colors via three channels – to nine-channel ‘direct’ color and intensity control
- Multiple dimming curve options
- Preset colors and sequences for stand-alone (no console required) operation
- White point selection – white light and color behavior based on a specific color temperature white light, i.e., 3200 K, 5600 K, etc
- Loss of data behavior options – instant off, hold last look for two minutes, etc
- Output modes – three output options that offer the user a choice between maximum output and maximum consistency

See the user manual for a complete explanation of all of the control settings and options for the D40XT Studio.

**Quick Setups**

Use one of five Quick Setups on the fixture display to get started. You can modify the setting as needed.

Setting Title	Profile	Description	Typical Features*
Studio	Studio	Studio factory default: Enables three parameter control of white light (intensity, white point, and tint) via DMX from console or from fixture display – no console required	<ul style="list-style-type: none"> <li>• Linear dimming curve</li> <li>• Regulated output mode for color consistency</li> </ul>
General	Direct	For general purpose use including interior architectural applications	<ul style="list-style-type: none"> <li>• Standard dimming curve</li> <li>• Regulated output for color consistency</li> </ul>
Stage	HSI Plus 7 Enabled	Theatrical lighting: Duplicates the color and dimming behavior of tungsten stage lighting fixtures.	<ul style="list-style-type: none"> <li>• Incandescent dimming curve</li> <li>• Regulated output for color consistency</li> <li>• 3200 K white point setting</li> </ul>
XT Arch	HSI	Exterior architectural lighting: Provides a high degree of color consistency in high ambient temperature environments.	<ul style="list-style-type: none"> <li>• Standard dimming curve</li> <li>• Protected output</li> <li>• 3200 K white point setting</li> </ul>
High Impact	RGB	Event lighting: Enables quickest response, simple RGB control and strobe channel for maximum effect usage	<ul style="list-style-type: none"> <li>• Quick dimming curve</li> <li>• Boost mode for maximum intensity</li> <li>• 5600 K white point setting</li> </ul>

\*See user manual for complete list of features for each Quick Setup

**CONTROL OPTIONS**

**Studio HD**

**DMX Input Channel Profiles**

DMX Profile	DMX Channels	Channel Assignments	Notes
Studio	3	1 – Intensity 2 – Color Point (CCT) 3 – Tint	Controls fixture as a white light unit. If no DMX, i.e. console input, is present, fixture can be adjusted for these three parameters on the UI at the back of the unit.
Direct	9	1 – Red 2 – Amber 3 – Green/Cyan 4 – Blue 5 – 3000 K White 6 – 5000 K White 7 – n/a 8 – Intensity 9 – Strobe	Direct control of each individual color with a separate master intensity channel. Color calibration of LEDs is not active in this mode. The nine-channel profile will produce the highest quality color cross-fades.
HSI	5	1 – Hue (coarse) 2 – Hue (fine) 3 – Saturation 4 – Intensity 5 – Strobe	High resolution hue (two-channels), saturation, and intensity control. HSI mode will produce color cross-fades around the color space.
HSIC	6	1 – Hue (coarse) 2 – Hue (fine) 3 – Saturation 4 – Intensity 5 – Strobe 6 – Color Point (CCT)	High-resolution hue, saturation and intensity control as above, with the addition of a color point channel to adjust the color temperature of the fixture in both white light and color. Color cross-fade performance is the same as HSI.
RGB	5 (Ch. 4 not used)	1 – Red 2 – Green 3 – Blue 4 – n/a 5 – Strobe	Effectively addresses all seven colors via three channels of control. RGB profile will produce medium quality color cross-fades

**Additional profile options**

Plus 7	Seven additional color control channels are available in RGB, HSI, HSIC, and Studio profile settings. For example HSI with ‘Plus 7’ enabled becomes a 14-channel profile:	1 – Hue (coarse) 2 – Hue (fine) 3 – Saturation 4 – Intensity 5 – Strobe 6 – n/a 7 – Plus 7 Control on/off 8 – Red 9 – Amber 10 – Green/Cyan 11 – Blue 12 – 3000 K White 13 – 6000 K White 14 – n/a	The desired color and intensity is achieved by using the HSI or RGB channels.  Placing channel seven at a value over 51% gives the fixture a 14-channel profile.  Channels 8-14 represent the native colors of the fixture and allow the operator to adjust individual color channels to fine tune the color output.
Strobe	Variable strobe control: 0% is no strobe. The fixture output will strobe more rapidly as the strobe channel value approaches 100%.		

**CONTROL OPTIONS**

**Studio Daylight and Studio Tungsten (only)**

**Quick Setups**

Setting Title	Profile	Description	Typical Features
Studio	Studio	Enables control of intensity from luminaire UI; no console required	<ul style="list-style-type: none"> <li>• Linear dimming curve</li> <li>• Regulated output for intensity stability</li> </ul>
Single Channel	Direct	For general purpose architectural use	<ul style="list-style-type: none"> <li>• Standard dimming curve</li> <li>• Regulated output for consistency</li> </ul>
Stage	Direct	Matches conventional luminaire performance	<ul style="list-style-type: none"> <li>• Incandescent dimming curve</li> <li>• Regulated output</li> </ul>

**DMX Input Channel Profiles**

DMX Profile	DMX Channels	Channel Assignments	Notes
Studio	3	1 – Intensity 2 – Strobe 3 – Fan Control (D60 only)	Control of parameters is also enabled from the luminaire's user interface. No console required.
Direct	3	1 – Intensity 2 – Strobe 3 – Fan Control (D60 only)	

**LENS INFORMATION**

**Desire diffusion angle measurements**

NOMINAL									
	No Lens	Very Narrow	Narrow	Medium	Wide	Extra Wide	Narrow Oval	Medium Oval	Wide Oval
<b>D40XT STUDIO</b>		25°	35°	45°	75°	N/A	20° x 40°	30° x 70°	35° x 80°
<b>LUSTR+</b>	22	26	32	54	77	97	29 x 43	33 x 63	33 x 97
<b>VIVID</b>	22	26	32	54	77	97	29 x 43	33 x 63	33 x 97
<b>STUDIO HD</b>	22	26	32	54	77	97	29 x 43	33 x 63	33 x 97
<b>STUDIO D</b>	31	33	38	60	81	97	36 x 48	41 x 68	35 x 97
<b>STUDIO T</b>	31	33	38	60	81	97	36 x 48	41 x 68	35 x 97

Values in black refer to old lens descriptions.

PHOTOMETRICS

D40XT Studio HD

Mode	Degree	Candela	Field Lumens	Beam Lumens	Lumens Per Watt
Boost Full	10.3°	79,390	3,194	1,296	33.2
Regulated Full	10.3°	74,890	3,015	1,197	33.0
Regulated 3200 K	10.3°	72,160	2,928	1,176	36.1
Regulated 5600 K	10.3°	59,459	2,477	951	32.1

Metric conversions: For meters, multiply feet by 0.3048.  
For lux, multiply foot-candles by 10.76.

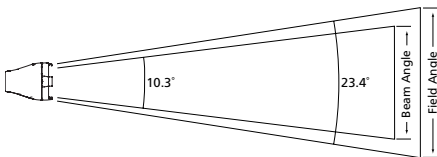

Throw Distance (d)	10.0 ft	15.0 ft	20.0 ft	30.0 ft	273.7 ft
	3.0 m	4.6 m	6.1 m	9.1 m	83.4 m
Field Diameter	4.1 ft	6.2 ft	8.3 ft	12.4 ft	-
	1.3 m	1.9 m	2.5 m	3.8 m	
Illuminance (fc)	749	333	187	83	1
Illuminance (lux)	8,061	3,583	2,015	896	10.76

To determine center beam illumination in foot-candles at any throw distance, divide candela by the throw distance squared.

For field diameter at any distance, multiply distance by 0.414.  
For beam diameter at any distance, multiply by 0.180.

Cosine Candela Plot

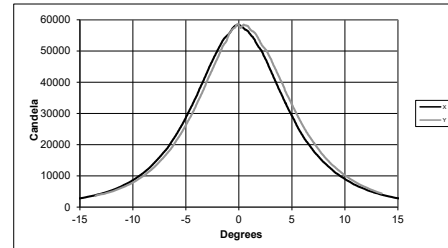

Iso-Illuminance Diagram (Flat Surface Distribution)

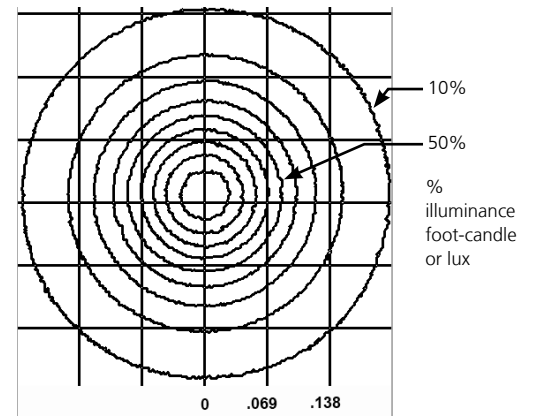

D40XT Studio Daylight

Mode	Degree	Candela	Field Lumens	Beam Lumens	Lumens Per Watt
Boost Full	12.6°	67,325	4,332	1,640	43.1
Regulated Full	12.6°	61,743	3,973	1,504	43.0

Metric conversions: For meters, multiply feet by 0.3048.  
For lux, multiply foot-candles by 10.76.

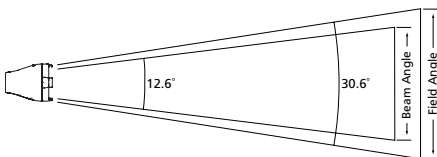

Throw Distance (d)	10 ft	15 ft	20 ft	30 ft	248.5 ft
	3.0 m	4.6 m	6.1 m	9.1 m	75.7 m
Field Diameter	5.5 ft	8.2 ft	10.9 ft	16.4 ft	-
	1.7 m	2.5 m	3.3 m	5.0 m	
Illuminance (fc)	617	274	154	69	1
Illuminance (lux)	6,646	2,954	1,661	738	10.76

To determine center beam illumination in foot-candles at any throw distance, divide candela by the throw distance squared.

For field diameter at any distance, multiply distance by 0.547.  
For beam diameter at any distance, multiply by 0.221.

Cosine Candela Plot

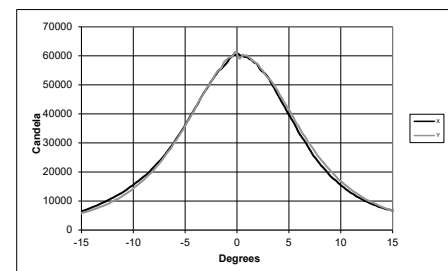

Iso-Illuminance Diagram (Flat Surface Distribution)

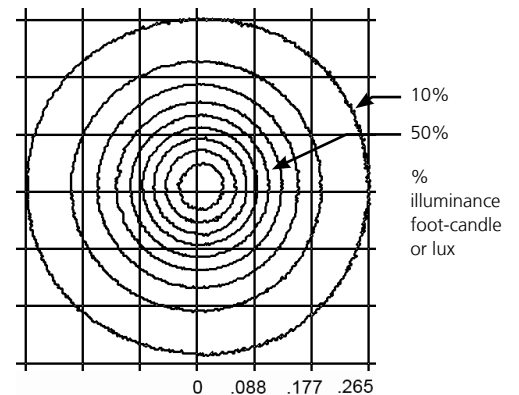



PHOTOMETRICS

D40XT Studio Tungsten

Mode	Degree	Candela	Field Lumens	Beam Lumens	Lumens Per Watt
Regulated Full	11.7	97,389	5,023	2,018	52.8

Metric conversions: For meters, multiply feet by 0.3048.  
For lux, multiply foot-candles by 10.76.

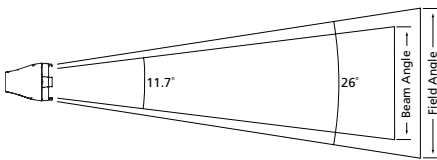

<b>Throw Distance (d)</b>	10 ft 3.0 m	15 ft 4.6 m	20 ft 6.1 m	30 ft 9.1 m	312.1ft 95.1 m
<b>Field Diameter</b>	4.6 ft 1.4 m	6.9 ft 2.1 m	9.2 ft 2.8 m	13.9 ft 4.2 m	—
<b>Illuminance (fc)</b>	974	433	243	108	1
<b>Illuminance (lux)</b>	10,483	4,659	2,621	1,165	10.76

For field diameter at any distance, multiply distance by 0.462.  
For beam diameter at any distance, multiply by 0.205.

Cosine Candela Plot

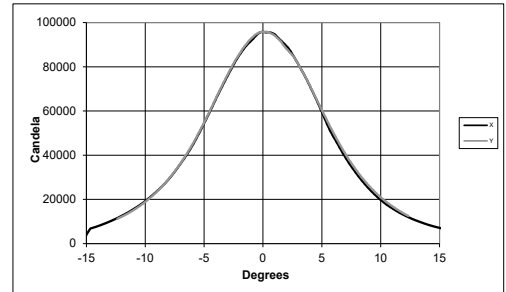

Iso-Illuminance Diagram (Flat Surface Distribution)

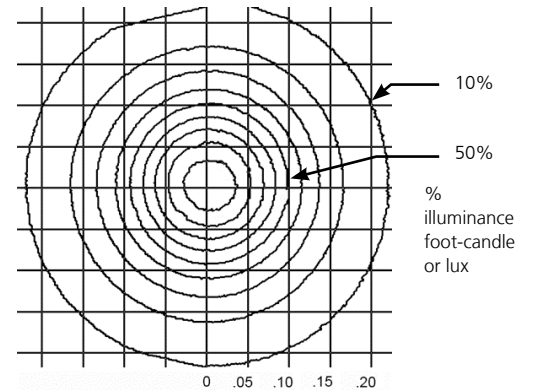

**THROW DISTANCE MULTIPLIER (TDM)**

To determine the distance from the center of the beam (Origin) to a certain illuminance level at a particular distance, multiply the desired throw distance by the TDM desired on the Iso-Illuminance diagram.

Throw Distance (TD) x Throw Distance Multiplier (TDM) = Distance from the Origin (DfO) (distance from the center of the beam)

Example: 25 feet (TD) x 0.047 (TDM) = 1.175 feet from center of beam (DfO)

For illumination with any lamp, multiply the candlepower of a beam spread by the multiplying factor (mf) shown for that lamp.

To determine illumination in foot-candles or lux at any throw distance, divide candlepower by distance squared.

PHYSICAL

Desire D40XT Studio Weights and Dimensions

WEIGHT*		SHIPPING WEIGHT	
lb	kg	lb	kg
14	6.4	17	7.8

\* Does not include mounting hardware

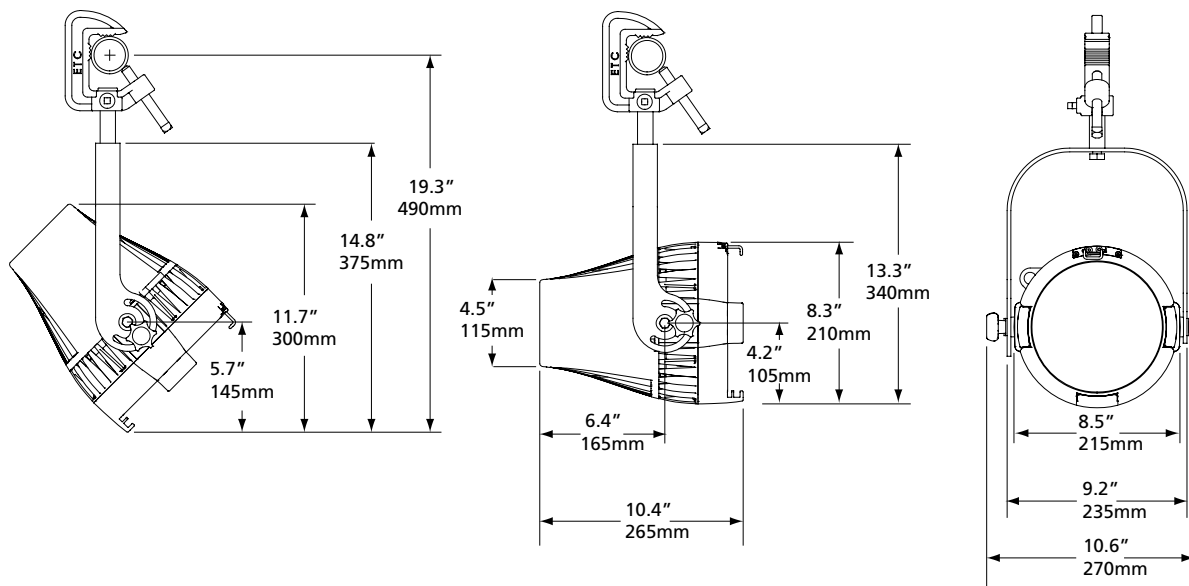

Note: D40XT Studio fixtures are equipped with attached 39" power and data leads



Corporate Headquarters • Middleton, WI USA

Global Offices • London, UK • Rome, IT • Holzkirchen, DE • Paris, FR • Hong Kong  
Dubai, UAE • Singapore • New York, NY • Orlando, FL • Los Angeles, CA • Austin, TX

Copyright©2021 ETC. All Rights Reserved. All product information and specifications subject to change. Rev T 2021-09

\*Trademark and patent info: [etcconnect.com/ETC](http://etcconnect.com/ETC)

[etcconnect.com](http://etcconnect.com)