



Type(s)

Project

Date

Notes

GENERAL INFORMATION

ETC Desire D40 Studio lighting fixtures use the newest technology in high-output white-light LEDs to create an ideal luminaire for video, film and other 'white light only' applications. Three different LED options give the user a choice for just the right white-light output for the job. The D40 Studio offers a rugged die-cast enclosure, noiseless fan-free operation, multiple lens options and an advanced user interface. The user interface enables easy configuration and specific features for video and film applications. The fixture can be configured to operate under console control for studio systems or in stand-alone 'no console required' mode for location lighting.

D40 STUDIO LED ARRAY OPTIONS

D40 Studio fixtures offer three different LED array choices based on specific white-light functions. The D40 Studio fixture is available with any one of the following arrays (not interchangeable) to best suit the intended application.

- D40 Studio HD – combines warm-white and cool-white LEDs for variable color temperature mixing. Added to this are five carefully chosen LED colors from the Selador x7 Color System to fill in the white LED spectral gaps. The high-intensity D40 Studio HD provides the richest variable-white light possible in an LED fixture and excellent color rendering
- D40 Studio Daylight – contains forty 5600 K LEDs for high-intensity, non-variable cool-white output
- D40 Studio Tungsten – contains forty 3000 K LEDs for high-intensity, non-variable warm-white output

ORDERING INFORMATION

Selador D40 Studio

MODEL	DESCRIPTION	ETL PART NUMBER	CE PART NUMBER	
SELD40HI	D40 Studio HD	7410A1402	7410A1402-0X	
SELD40DI	D40 Studio Daylight	7410A1407	7410A1407-0X	
SELD40TI	D40 Studio Tungsten	7410A1406	7410A1406-0X	

Note: D40 luminaires ship with a hanging yoke and an input lead with a connector of choice. See page 6 for connector options. C-clamps are not included.

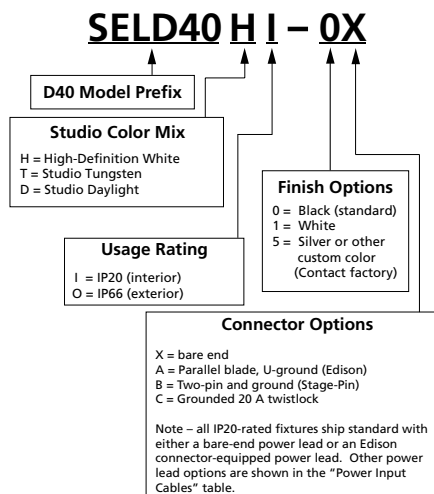

PRODUCT SPECIFICATIONS

Source

LED details	40 Lumileds LUXEON® Rebel LED
Max lumens	Studio HD: 3,194 Studio Daylight: 4,332 Studio Tungsten: 5,023
Lumens per watt	Studio HD: 33.2 Studio Daylight: 43.1 Studio Tungsten: 52.8
L70 rating (hours to 70% output)	50,000 hours

Color

Colors used	Studio HD: Red, Amber, Green/Cyan, Blue, Warm White, Cool White Studio Daylight: White Studio Tungsten: White
Color temperature range	Studio HD: 2700–5600 K Studio Daylight: 3200 K Studio Tungsten: 5600 K
Calibrated array	Studio HD: Yes Studio Daylight: No Studio Tungsten: No
Red shift	Yes (Studio HD)

Optical

Beam angle	11°
Aperture size	7.5 in
Pattern projection	No
Pattern size	N/A
Camera flicker control/Hz range	Yes: 900–25,000 Hz
Notes	Secondary lenses available for multiple beam-spread options

Control

Input method	DMX512 via 5-pin XLR
Protocols	DMX512/RDM
Modes (footprint)	See page 6
RDM configuration	Yes
UI type	LCD
Local control	Yes
Onboard presets	Yes
Onboard sequences	Yes
Onboard effects	No
Fixture-to-fixture control	Yes
Notes	15-bit virtual dimming engine

Electrical

Voltage range	100–240 VAC 50/60 Hz
Input method	Neutrik powerCON in and thru Requires power from non-dim source
Inrush (first half-cycle)	15 A at 120 V 40 A at 240 V
Fixtures per circuit	10 (15 A via power thru)*
Wattage (typical)	104
Current draw	0.88 A at 120 V 0.42 A at 240 V

*Note: All measurements are for 120 V, 60 Hz. Results may vary in different regions.

Thermal

Ambient operating temp	-20°–40°C (-4°–104°F)
Fan (controllable)	No
Droop compensation	Yes
dB range	N/A
BTUs/hour	375.32

Physical

Materials	Die-cast, all metal housing
Color options	Black, white, silver, or custom color
Mounting options	Yoke
IP rating	IP20
Weight	6.4 kg (14 lb)
Included accessories	Hanging yoke, optional yoke/floor stand
Notes	Easy access slots for secondary lenses and standard 7.5 inch PAR accessories

Warranty

Fixture	5 years
LED array	10 years

Regulatory and Compliance

Approved regulatory standards	UL 1573 CSA C22.2 No. 166 CE Compliant EAC Compliant
-------------------------------	---

ETC utilizes a nationally recognized third-party lab for luminaire testing according to IES LM-84. See etconnect.com/About/News/ETC-Fixture-Ratings-and-Warranties-Extended.aspx.

All LED sources experience some lessening of light output and some color shift over time. LED output will vary with thermal conditions. In individual situations, LEDs will be used for different durations and levels. This can eventually lead to minor alterations in color performance, necessitating slight adjustments to presets, cues or programs.

PRODUCT FEATURES



NOISELESS, FAN-FREE
Convection cooling for acoustically sensitive installations.



MULTIPLE LED ARRAY OPTIONS
Available in Daylight, Tungsten, and HD so you can get the white light you need.

a decade of coverage



INDUSTRY LEADING WARRANTY
Unmatched five year fixture and ten year warranty on the LED array.

COLOR METRIC INFORMATION

D40 STUDIO HD 3200 K TM-30-18

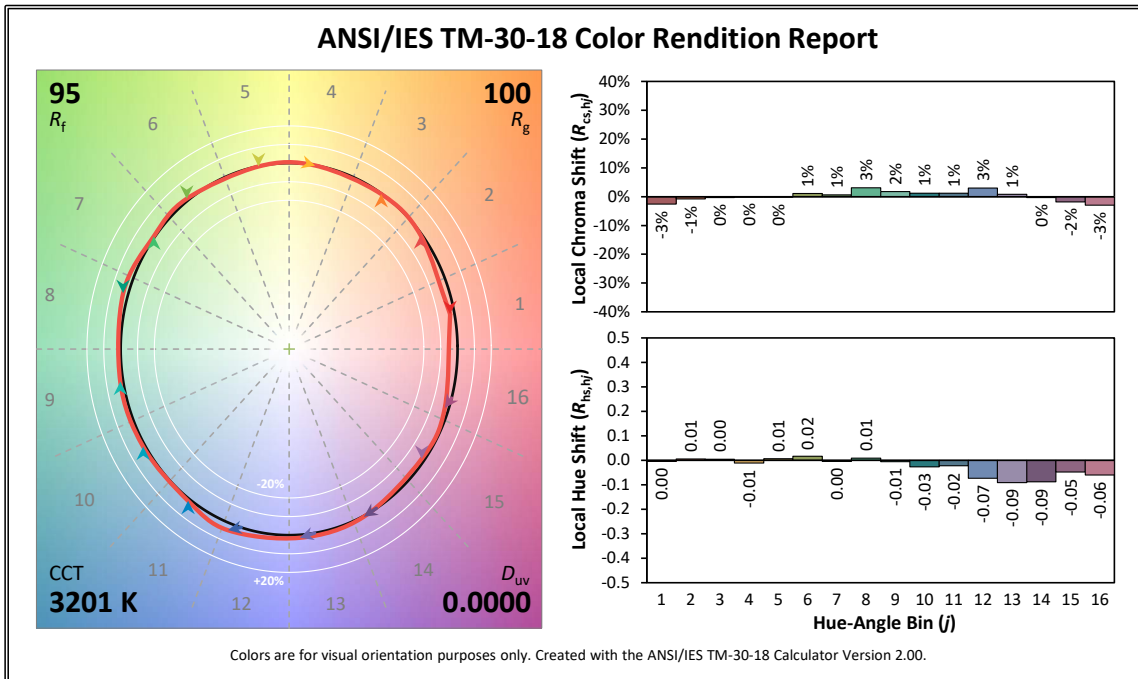

COLOR METRIC INFORMATION

D40 STUDIO HD 4500 K TM-30-18

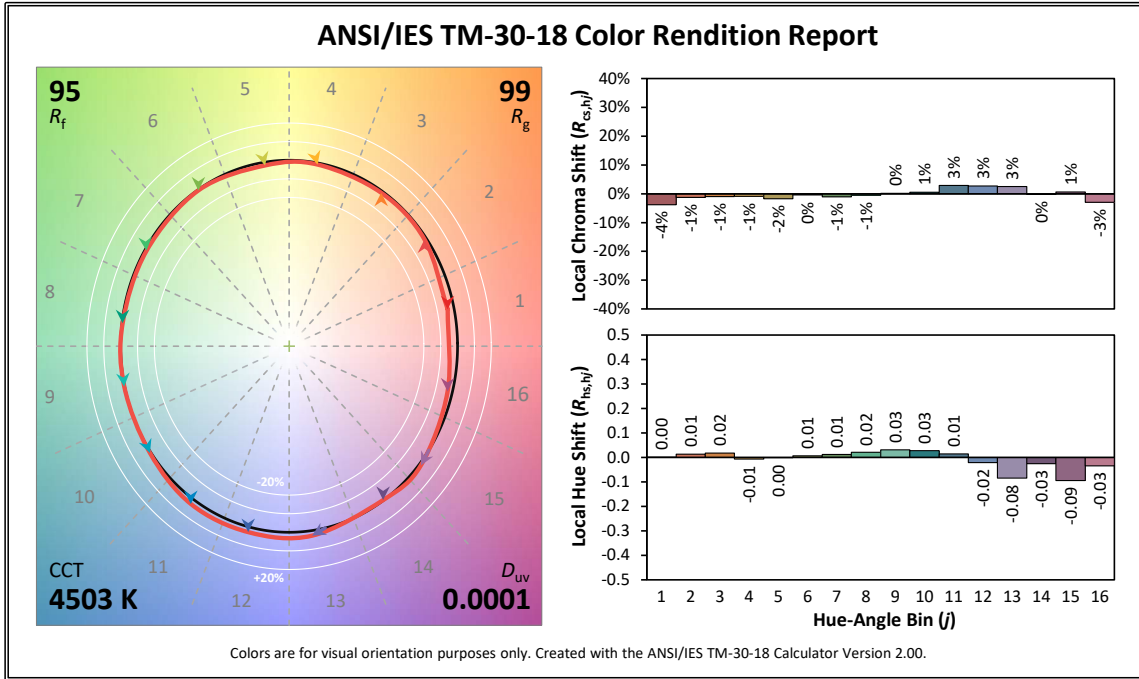

D40 STUDIO HD 5600 K TM-30-18

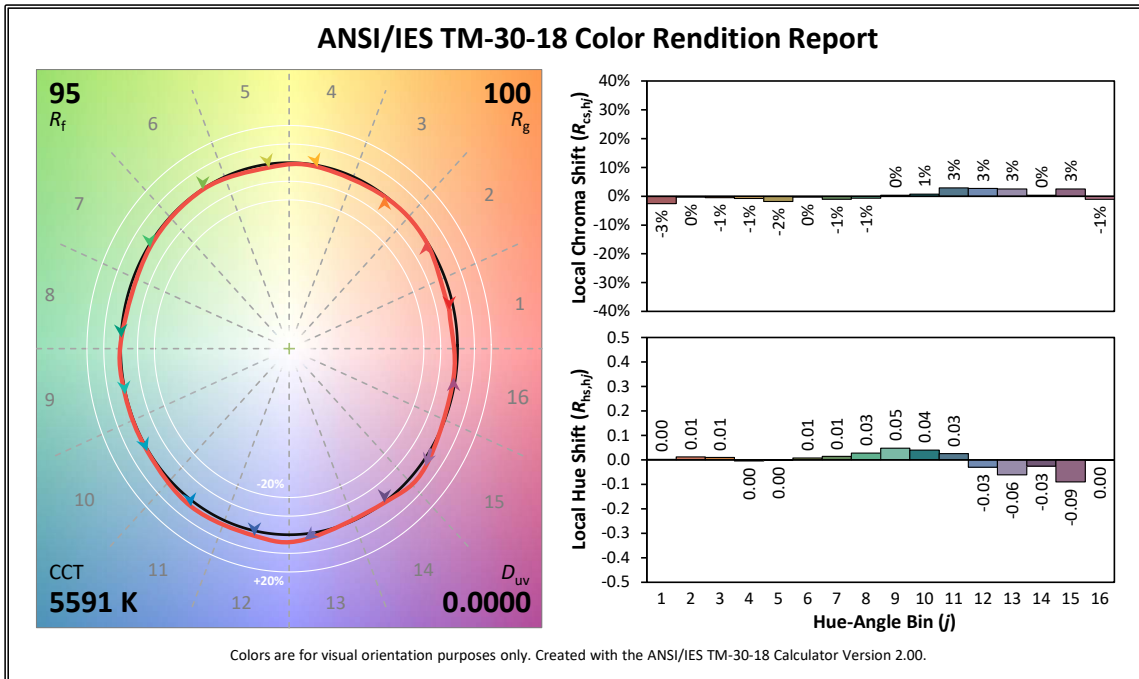

ADDITIONAL ORDERING INFORMATION
SECONDARY LENS OPTIONS

The following lenses are cut for D40 fixtures and create round, linear or oblong field patterns as described below. These lenses are not sized for use in Selador Classic fixtures.

Note: This is the same material as Selador Classic lenses.

MODEL	DESCRIPTION	PART NUMBER	
Narrow Linear Field	Linear lenses may be combined to create desired field size		
SELLN-7.5	7.5 in narrow lens	7410K1018	
SELLM-7.5	7.5 in medium lens	7410K1019	
SELLW-7.5	7.5 in wide lens	7410K1020	
SELLEW-7.5	7.5 in extra wide lens	7410K1021	
Round Field			
SELRN-7.5	7.5 in narrow lens (round field)	7410K1011	
SELRM-7.5	7.5 in medium lens (round field)	7410K1012	
SELRW-7.5	7.5 in wide lens (round field)	7410K1013	
SELRXW-7.5	7.5 in extra wide lens (round field)	7410K1039	
Oblong Field			
SELON-7.5	7.5 in narrow lens (oblong field)	7410K1014	
SELOM-7.5	7.5 in medium lens (oblong field)	7410K1015	
SELOW-7.5	7.5 in wide lens (oblong field)	7410K1016	

[Desire lenses compared to Source Four PAR EA](#)

ADDITIONAL ORDERING INFORMATION
Power Input Cables

Use information below to order 5 ft power input leads with factory-fitted connectors. CE Fixtures ship with powerCON to bare end cable in the box.

MODEL	DESCRIPTION	
DPA-A	5 ft powerCON to parallel blade U-ground (Edison) connector	
DPA-B	5 ft powerCON to 20 A two-pin and ground (stage pin) connector	
DPA-C	5 ft powerCON to grounded 20 A twistlock connector	
DPA-X	5 ft powerCON to bare-end power input lead	

Power Thru Jumpers

Note: Power thru jumpers connect to fixture's output (thru) connector to provide link to successive fixtures

MODEL	DESCRIPTION	PART NUMBER	
DPJ-5	5 ft powerCON to PowerCON fixture to fixture jumper	7410B7020	
DPJ-10	10 ft powerCON to PowerCON fixture to fixture jumper	7410B7010	

Fixtures Accessories

MODEL	DESCRIPTION	PART NUMBER	
SELD40FSY	Yoke with floor-stand attachment	7410K1003	
400BD	Barn door (Use only as a flexible top hat to diminish aperture glare. Not for beam shaping)	PSF1019	
407CF	Color frame (use for round and oblong lenses)	7061A3007	
400L	Egg crate louver	PSF1028	
400PTH3	Top hat 3 in tube	PSF1022	
400PTH6	Top hat 6 in tube	PSF1023	
400PHH	Half hat 6 in tube	PSF1027	
400CC	C-Clamp (does not ship with fixture)	7060A2009 (not CE)	
400SC	Safety cable (32 in)	7060A1022	
DPSJ-25	25 ft powerCON to Edison input power cable with inline switch	7400B7030	

NOTES ABOUT LED LUMINAIRES

CRI AND CQS RATINGS

Desire fixtures were evaluated for CRI and CQS performance using measured output spectrum and optimized mix solutions for a best spectral match to black body sources at 3200 K and 5600 K.

Fixture	CRI	CQS	Color Fidelity	Duv
D40 Vivid at 3200K	87	89	89	0.000
D40 Vivid at 5600K	90	92	92	0.000
D40 Lustr+ at 3200K	86	88	88	0.000
D40 Lustr+ at 5600K	93	92	90	0.000
D40 Studio HD at 3200K	89	90	91	0.000
D40 Studio HD at 5600K	92	94	94	0.000
D40 Studio Daylight at 5600K	71	70	69	0.001
D40 Studio Tungsten at 3000K	86	86	86	0.001

All D40 Studio luminaire versions provide excellent color rendering to the eye, particularly at higher color temperature settings such as 5600 K. In most cases the Duv is 0.000. A Duv rating of 0.000 indicates that the color mix used is exactly on the black body line, with no green or magenta tint.

Notes to videographers:

- All Desire fixtures use Luxeon Rebel ES emitters specified by the strictest binning standards. However, on-camera LED response varies with different cameras and settings. Daylight LEDs can appear slightly greener than other 5600 K sources on camera.
- Fixtures with non-variable single-color daylight arrays, such as Studio Daylight, may use standard color correction filters (Rosco 3314, Rosco 3316 or similar) to achieve the desired on-camera result.
- Camera tests using your specific setup are recommended to determine the best configuration.

CONTROL OPTIONS

User settings on D40 Studio fixtures allow multiple operational modes and settings for either console operation via DMX protocol or stand-alone operation. The expanded LCD display provides easy navigation to all possible settings and options. Some of them are:

- Multiple DMX choices ranging from a simple RGB profile, which effectively controls all seven LED colors via three channels – to nine-channel direct color and intensity control
- Multiple dimming curve options
- Preset colors and sequences for stand-alone (no console required) operation
- White point selection – white light and color behavior based on a specific color-temperature white light, i.e. 3200 K, 5600 K, etc.
- Loss of data behavior options – instant off, hold last look for two minutes, etc.
- Output modes – three output options that offer the user a choice between maximum output and maximum consistency

See the user manual for a complete explanation of all of the control settings and options for the D40 Studio.

Quick Setups

Use one of five Quick Setups on the fixture display to get started. You can modify the setting as needed.

Setting Title	Profile	Description	Typical Features*
Studio	Studio	Studio factory default: Enables three-parameter control of white light (intensity, white point, and tint) via DMX from a console or console-free from a fixture display	<ul style="list-style-type: none"> • Linear dimming curve • Regulated output mode for color consistency
General	Direct	For general-purpose use, including interior architectural applications	<ul style="list-style-type: none"> • Standard dimming curve • Regulated output for color consistency • 3200 K white-point setting
Stage	HSI Plus 7 Enabled	Theatrical lighting: Duplicates the color and dimming behavior of tungsten stage lighting fixtures	<ul style="list-style-type: none"> • Incandescent dimming curve • Regulated output for color consistency • 3200 K white-point setting
XT Arch	HSI	Exterior architectural lighting: Provides a high degree of color consistency in high ambient-temperature environments	<ul style="list-style-type: none"> • Standard dimming curve • Protected output • 3200 K white-point setting
Hight Impact	RGB	Event lighting: Enables quickest response, simple RGB control and strobe channel for maximum effect usage	<ul style="list-style-type: none"> • Quick dimming curve • Boost mode for maximum intensity • 5600 K white-point setting

*See user manual for complete list of features for each Quick Setup

CONTROL OPTIONS

DMX Input Channel Profiles

DMX Profile	DMX Channels	Channel Assignments	Notes
Studio	3	1 – Intensity 2 – Color Point (CCT) 3 – Tint	Controls fixture as a white light unit. If no DMX is present (console input, for example), fixture can be adjusted for these three parameters on the user interface at the back of the unit
Direct	9	1 – Red 2 – Amber 3 – Green/Cyan 4 – Blue 5 – 3000 K White 6 – 6000 K White 7 – n/a 8 – Intensity 9 – Strobe	Direct control of each individual color with a separate master intensity channel. Color calibration of LEDs is not active in this mode. The nine-channel profile will produce the highest-quality color crossfades
HSI	5	1 – Hue (coarse) 2 – Hue (fine) 3 – Saturation 4 – Intensity 5 – Strobe	High-resolution hue (two channels), saturation, and intensity control. HSI mode will produce color crossfades around the color space
HSIC	6	1 – Hue (coarse) 2 – Hue (fine) 3 – Saturation 4 – Intensity 5 – Strobe 6 – Color Point (CCT)	High-resolution hue, saturation and intensity control as above, with the addition of a color-point channel to adjust the color temperature of the fixture in both white light and color. Color crossfade performance is the same as HSI
RGB	5 (Ch. 4 not used)	1 – Red 2 – Green 3 – Blue 4 – n/a 5 – Strobe	Effectively addresses all seven colors via three channels of control. RGB profile will produce medium-quality color crossfades
Additional profile options			
Plus 7		Seven additional color control channels are available in RGB, HSI, HSIC, and Studio profile settings. For example, HSI with 'Plus 7' enabled becomes a 14-channel profile:	
		1 – Hue (coarse) 2 – Hue (fine) 3 – Saturation 4 – Intensity 5 – Strobe 6 – n/a 7 – Plus 7 Control on/off 8 – Red 9 – Amber 10 – Green/Cyan 11 – Blue 12 – 3000 K White 13 – 6000 K White 14 – n/a	The desired color and intensity are achieved by using the HSI or RGB channels. Placing channel seven at a value over 51% gives the fixture a 14-channel profile. Channels 8–14 represent the native colors of the fixture and allow the operator to adjust individual color channels to fine tune the color output.
Strobe		Variable strobe control: 0% is no strobe. The fixture output will strobe more rapidly as the strobe channel value approaches 100%.	

CONTROL OPTIONS

Studio Daylight and Studio Tungsten only

Quick setups

Setting Title	Profile	Description	Typical Features
Studio	Studio	Enables control of intensity from luminaire's user interface; no console required	<ul style="list-style-type: none"> • Linear dimming curve • Regulated output for intensity stability
Single Channel	Direct	For general-purpose architectural use	<ul style="list-style-type: none"> • Standard dimming curve • Regulated output for color consistency
Stage	Direct	Matches conventional luminaire performance	<ul style="list-style-type: none"> • Incandescent dimming curve • Regulated output

DMX input channel profiles

DMX Profile	DMX Channels	Channel Assignments	Notes
Studio	2	1 – Intensity 2 – Strobe	Control parameters from the luminaire's user interface. No console required.
Direct	2	1 – Intensity 2 – Strobe	

LENS INFORMATION

Desire diffusion angle measurements

NOMINAL									
	No Lens	Very Narrow	Narrow	Medium	Wide	Extra Wide	Narrow Oval	Medium Oval	Wide Oval
D40 STUDIO		25°	35°	45°	75°	N/A	20° x 40°	30° x 70°	35° x 80°
LUSTR+	22	26	32	54	77	97	29 x 43	33 x 63	33 x 97
VIVID	22	26	32	54	77	97	29 x 43	33 x 63	33 x 97
STUDIO HD	22	26	32	54	77	97	29 x 43	33 x 63	33 x 97
STUDIO D	31	33	38	60	81	97	36 x 48	41 x 68	35 x 97
STUDIO T	26	33	38	60	81	97	36 x 48	41 x 68	35 x 97

Values in black refer to old lens descriptions.

PHOTOMETRICS

D40 Studio HD

Mode	Degree	Candela	Field Lumens	Beam Lumens	Lumens Per Watt
Boost Full	10.5°	65,670	2,492	939	24.0
Regulated Full	10.5°	61,518	2,334	880	24.0
Regulated 3200 K	10.5°	42,089	1,597	602	23.4
Regulated 5600 K	10.5°	43,543	1,652	623	23.9

Metric conversions: For meters, multiply feet by 0.3048.
For lux, multiply foot-candles by 10.76.

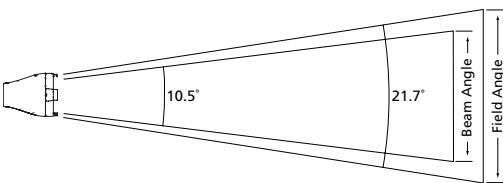

Throw Distance (d)	10.0 ft 3.0 m	15.0 ft 4.6 m	20.0 ft 6.1 m	30.0 ft 9.1 m	248 ft 75.6 m
Field Diameter	3.8 ft 1.2 m	5.7 ft 1.8 m	7.7 ft 2.3 m	11.5 ft 3.5 m	
Illuminance (fc)	615	273	154	68	1
Illuminance (lux)	6,622	2,943	1,655	736	10.76

To determine center beam illumination in foot-candles at any throw distance, divide candela by the throw distance squared.

For field diameter at any distance, multiply distance by 0.383.
For beam diameter at any distance, multiply by 0.184.

Cosine Candela Plot

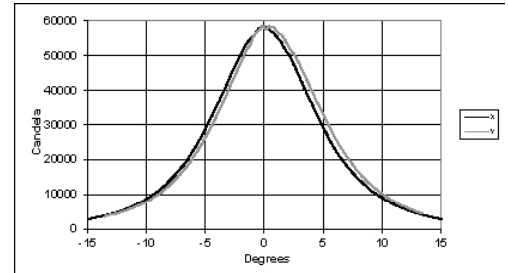

Iso-Illuminance Diagram (Flat Surface Distribution)

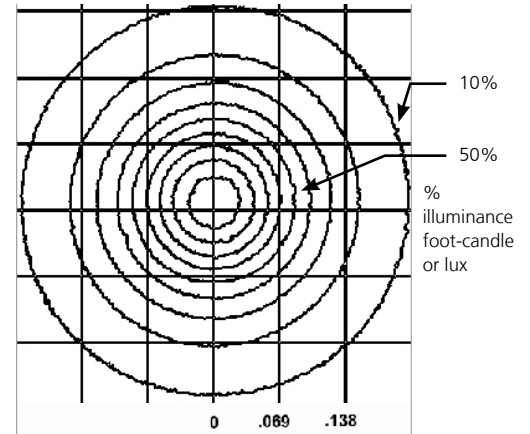

D40 Studio Daylight

Mode	Degree	Candela	Field Lumens	Beam Lumens	Lumens Per Watt
Boost Full	12.6°	67,325	4,332	1,640	43.1
Regulated Full	12.6°	61,743	3,973	1,504	43.0

Metric conversions: For meters multiply feet by 0.3048.
For lux multiply foot-candles by 10.76.

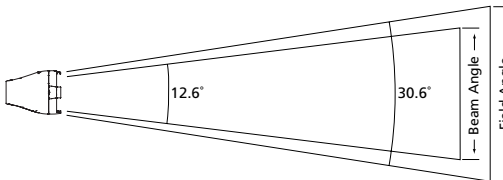

Throw Distance (d)	10 ft 3.0 m	15 ft 4.6 m	20 ft 6.1 m	30 ft 9.1 m	248.5 ft 75.7 m
Field Diameter	5.5 ft 1.7 m	8.2 ft 2.5 m	10.9 ft 3.3 m	16.4 ft 5.0 m	
Illuminance (fc)	617	274	157	69	1
Illuminance (lux)	6,646	2,954	1,661	738	10.76

To determine center beam illumination in foot-candles at any throw distance, divide candela by the throw distance squared.

For field diameter at any distance, multiply distance by 0.547.
For beam diameter at any distance, multiply by 0.221.

Cosine Candela Plot

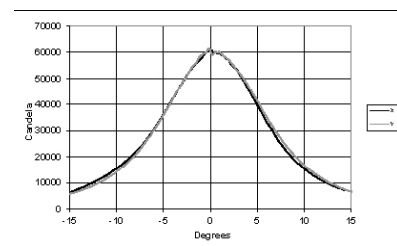

Iso-Illuminance Diagram (Flat Surface Distribution)

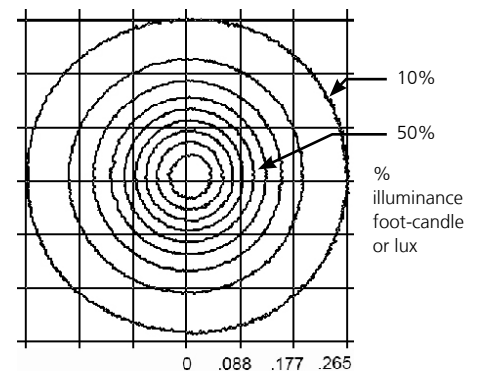

PHOTOMETRICS

D40 Studio Tungsten

Mode	Degree	Candela	Field Lumens	Beam Lumens	Lumens Per Watt
Boost Full	12.6°	52,757	3,297	1,203	31.3
Regulated Full	12.6°	50,351	3,147	1,148	30.9

Metric conversions: For meters, multiply feet by 0.3048.
 For lux, multiply foot-candles by 10.76.

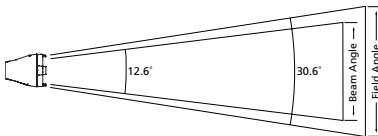

Throw Distance (d)	10.0 ft 3.0 m	15.0 ft 4.6 m	20.0 ft 6.1 m	30.0 ft 9.1 m	224.4 ft 68.4 m
Field Diameter	5.5 ft 1.7 m	8.2 ft 2.5 m	10.9 ft 3.3 m	16.4 ft 5.0 m	
Illuminance (fc)	504	224	126	56	1
Illuminance (lux)	5,420	2,409	1,355	602	10.76

To determine center beam illumination in foot-candles at any throw distance, divide candela by the throw distance squared.

For field diameter at any distance, multiply distance by 0.547.
 For beam diameter at any distance, multiply by 0.221.

THROW DISTANCE MULTIPLIER (TDM)

To determine the distance from the center of the beam (Origin) to a certain illuminance level at a particular distance, multiply the desired throw distance by the TDM desired on the Iso-Illuminance diagram.

Throw Distance (TD) x Throw Distance Multiplier (TDM) = Distance from the Origin (DfO) (distance from the center of the beam)

Example: 25 feet (TD) x 0.047 (TDM) = 1.175 feet from center of beam (DfO)

For illumination with any lamp, multiply the candlepower of a beam spread by the multiplying factor (mf) shown for that lamp.

To determine illumination in footcandles or lux at any throw distance, divide candlepower by distance squared.

Cosine Candela Plot

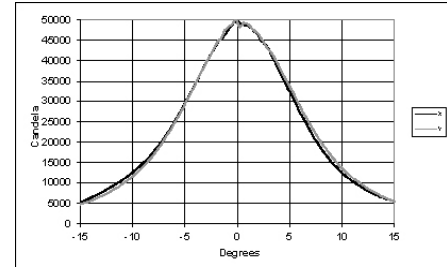

Iso-Illuminance Diagram (Flat Surface Distribution)

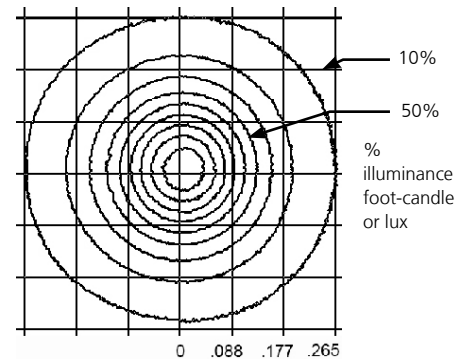

PHYSICAL

Selador Desire D40 Studio Weights and Dimensions

WEIGHT*		SHIPPING WEIGHT	
lb	kg	lb	kg
14	6.4	17	7.8

* Does not include mounting hardware

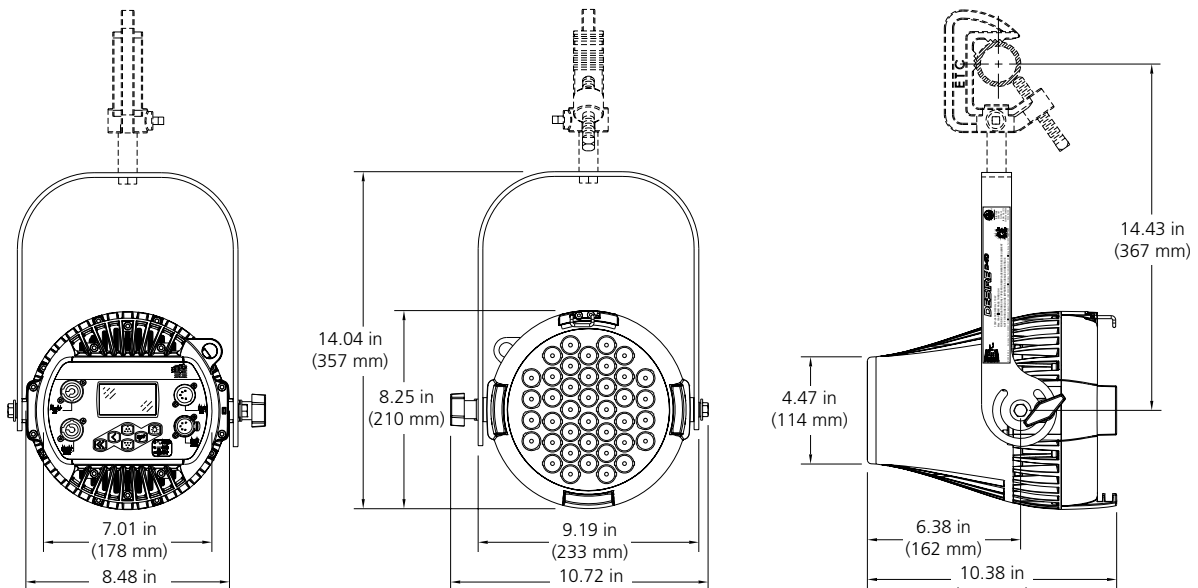

Corporate Headquarters • Middleton, WI USA

Global Offices • London, UK • Rome, IT • Holzkirchen, DE • Paris, FR • Hong Kong
Dubai, UAE • Singapore • New York, NY • Orlando, FL • Los Angeles, CA • Austin, TX

Copyright©2021 ETC. All Rights Reserved. All product information and specifications subject to change. Rev U 2021-09

*Trademark and patent info: etcconnect.com/ETC

etcconnect.com