

Version 1.13
January 31, 2018

User manual
PowerGate
Arma

PGA-O-D, PGA-O-2D, PGA-O-4D

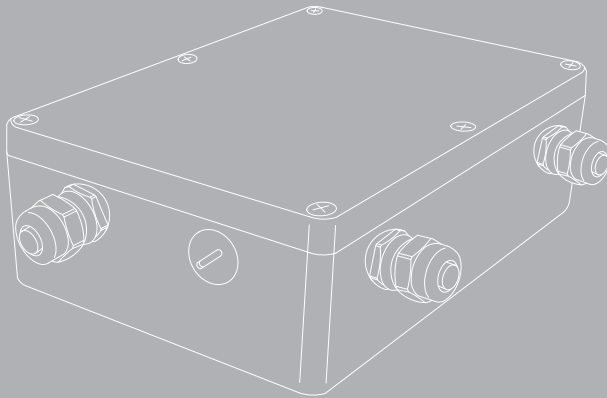
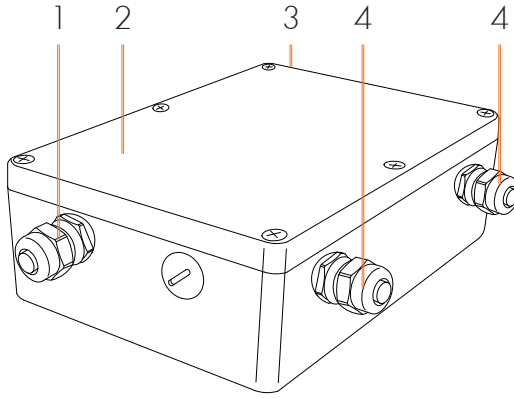

Table of contents

- 1 Visual appearance
- 1 Specifications
- 2 Safe operation
- 2 General information
- 3 Installation
- 5 Connection scheme
- 6 Technical maintenance
- 6 Transport and storage

Visual appearance



Pic.1 Location of device interfaces and indicators

1	Ethernet Input	3	Power input
2	Removable lid	4	DMX IN/OUT

Specifications

Supported protocols	DMX512, RDM, PWR DMX
DMX data refresh rate	44 Hz
DMX ports	1, 2 or 4 isolated
DMX connectors	Terminal blocks 15EDGVC
Input Power (max)	5 W
Power supply	~100-270 V, 50/60 Hz
Mains fuse	0,1 A
Setup	Web interface
Working temperatures	-40...+70°C
Ingress protection	IP 65
Dimensions and mounting	171 x 55 x 121 mm on surface/truss

Safe operation



WARNING!

The device uses hazardous voltage AC 230 V

To ensure safe and reliable operation of the devices, please observe the following requirements:

- Use the device only for its intended purpose;
- Do not use devices that show signs of malfunctioning;
- Avoid strong physical impacts on the device;
- Protect devices and cables from contact with corrosive liquids.

Whenever a fault is detected in the device, please contact the manufacturer.

General information

PowerGate is a series of transceivers employing existing power lines (110V/220V) to transmit DMX signal using PWRDMX technology introduced by Sundrax. PWRDMX eliminates the need of new cabling. Connected to the same power network, PowerGate devices form a network for reliable high speed communication.

Key features:

- DMX512 via 220/110 V transceiver
- Die-cast metal casing
- No buttons
- Full galvanic isolation
- Up to 400 m transmission range.

The devices supplied are configured as data transmitters to the 230/110V power line (hereinafter referred to as the «transmitter») or as data receivers from line (hereinafter referred to as the «receiver»).

Transmitter has 1, 2 or 4 input DMX ports for receiving DMX data from the lighting desks, other converters, etc.

Upon inputting proper DMX signal the transmitter starts to send DMX data via power line. If one or more PowerGate receivers are connected to the same power network segment, they will receive data from power line and output these data as DMX signal. DMX output signal from the receivers may be connected to fixtures or other converters in a normal way.

If transmitter has 2 or 4 ports, each of these is operating independently: DMX data from input 1 are transmitted to output 1 of all connected receivers, data from input 2- to output 2 of all receivers, etc.

The set of PowerGate devices needed for installation is delivered pre-configured with proper number of transmitters and receivers, so customer should only connect them to power line.

If network configuration change is needed for example, increasing the number of receivers, switching device's function from receiver to transmitter and back, creating two or more separated networks in one power line, etc., PowerGate's Ethernet input port is used.

PowerGate features LSA-PLUS-type connector for making temporary or permanent connection to computer/local network. Network setup is performed via web-interface of device, in the same way as for ArtGate devices. Please refer to ArtGate manual.

Installation

Before mounting and power up, it is necessary to verify protective earthing and cable connections.

1. Visually inspect the device to make sure that there are no transportation damages.
2. Connect the first device in transmitter mode to DMX signal source, and the second device in receiver mode to DMX-controlled equipment.
3. Connect AC power cable of the device to a power outlet in the network segment which is selected for work. There should be no reactive components such as transformers, surge protectors, etc. between the power sockets transmitter and receiver connected to.

Operation

Normal operation of the device in any mode starts immediately after switching power on.

Transmitter Operation

1. At power-on the transmitter connects to all receivers connected to all receivers from the same segment of power network. If the DMX data stream at the input connector of this channel is correct the LED associated with it lights steadily green. If there is no data stream the LED starts blinking.

2. DMX512 data taken by the transmitter from the input connector are transmitted to all connected receivers.

Receiver Operation

1. At power-on the receiver waits for a connection request from the transmitter. In this state the green LEDs on it lights steadily.

2. When connected to the transmitter the receiver LEDs start blinking on every data reception. DMX512 data received from network are sent to the output interface.

Troubleshooting

The list of possible faults and their troubleshooting methods.

Fault Name, Visual Signs	Possible Reasons	Troubleshootings
The device does not work, neither of the LEDs are lit	There is no supply voltage	Connect the device to a working power outlet
	Supply line fuse is broken	Replace the supply line fuse
No data transmission between the transmitter and one or more receivers	The receivers are in another network segment	Check the network, put devices to the same mains segment
	There are reactive elements present in the segment	Check the network, remove reactive load

Connection scheme

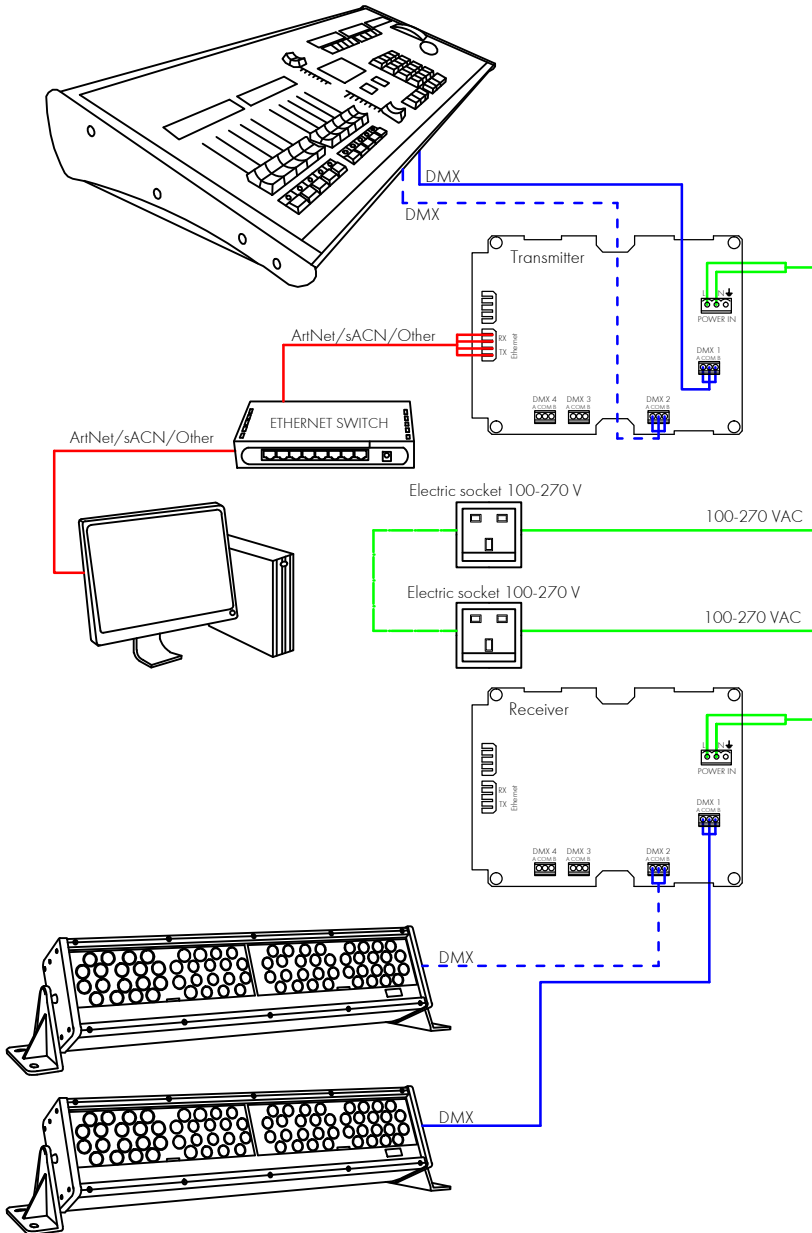

Technical maintenance

Maintenance the device, search and troubleshooting should be performed by service personnel. The device should be free from dirt, dents, connecting cables and wires must be intact and securely fastened.

Transport and storage

The device, packaged in containers should be stored in warehouses under conditions:

- temperatures from -50°C to $+80^{\circ}\text{C}$;
- relative humidity 95% ;
- the vapor acids, alkalis and other aggressive substances is not allowed.

Please send all your warranty-related questions to
support@sundrax.com
All Sundrax products are covered by a 36 months warranty.



Sundrax Electronics,
6008, First Central 200
2 Lakeside Drive, Park Royal, London
NW10 7FQ United Kingdom
+ 44 (0) 208 991 33 19
office@sundrax.com
www.sundrax.com